

# Capsule pressure gauge, stainless steel

## For the process industry

### Models 632.50 and 633.50, NS 63 [2 ½"], 100 [4"], 160 [6"]

WIKA data sheet PM 06.03



For further approvals,  
see page 8

### Applications

- For gaseous, dry and aggressive media, also in aggressive environments
- Process industry: Chemical, petrochemical, pharmaceutical, biotechnology, machine and power generation industries

### Special features

- Zero point correction in front
- Completely from stainless steel
- With liquid-filled case for applications with high dynamic pressure loads and vibrations (model 633.50)
- Low scale ranges from 0 ... 2.5 mbar to 0 ... 600 mbar or 0 ... 1 inH<sub>2</sub>O to 0 ... 240 inH<sub>2</sub>O



Capsule pressure gauge model 632.50

### Description

The model 632.50 and 633.50 capsule pressure gauges are completely manufactured from stainless steel and are therefore particularly suited for applications in the process industry. They are based upon the proven capsule measuring system. On pressurisation, the expansion of the capsule element, proportional to the incident pressure, is transmitted to the movement and indicated.

The modular design enables a multitude of combinations of case materials, process connections, nominal sizes and scale ranges. Due to this high variance, the instrument is suitable for use in a wide range of applications in the process industry.

For mounting in control panels, the capsule pressure gauges can, depending on the process connection, be fitted with a mounting flange or with a triangular profile ring and mounting bracket.

The model 633.50 with liquid-filled case is suitable for high dynamic pressure loads and vibrations.

The scale ranges of 0 ... 2.5 mbar to 0 ... 600 mbar or 0 ... 1 inH<sub>2</sub>O to 0 ... 240 inH<sub>2</sub>O and the vacuum and +/- scale ranges ensure the measuring ranges required for a wide variety of applications.

## Specifications

Basic information	
<b>Standard</b>	EN 837-3 For information on the "Selection, installation, handling and operation of pressure gauges", see technical information IN 00.05.
<b>Further version</b>	<ul style="list-style-type: none"> <li>■ For oxygen, oil- and grease-free</li> <li>■ Per NACE <sup>1)</sup> MR0175 / ISO 15156, use in H<sub>2</sub>S-containing environments in oil and gas production</li> <li>■ With integrated inductive contact, model 831 for model 632.50.100 and scale range <math>\geq 0 \dots 100</math> mbar [0 ... 40 inH<sub>2</sub>O] For information on switch contacts, see technical information IN 00.48</li> </ul>
<b>Nominal size (NS)</b>	<ul style="list-style-type: none"> <li>■ <math>\varnothing 63</math> mm [2 ½"]</li> <li>■ <math>\varnothing 100</math> mm [4"]</li> <li>■ <math>\varnothing 160</math> mm [6"]</li> </ul>
<b>Connection location</b>	<ul style="list-style-type: none"> <li>■ Lower mount (radial)</li> <li>■ Lower back mount</li> <li>■ Centre back mount (only for NS 63 [2 ½"])</li> </ul>
<b>Window</b>	<ul style="list-style-type: none"> <li>■ Laminated safety glass</li> <li>■ Polycarbonate (with case filling)</li> </ul>
<b>Case</b>	
Design	Safety level "S1" per EN 837-3 With blow-out device in case back (only for NS 100 [4"] and NS 160 [6"])
Material	<ul style="list-style-type: none"> <li>■ Stainless steel 1.4301 (304)</li> <li>■ Stainless steel 1.4571 (316Ti)</li> </ul>
Ring	<ul style="list-style-type: none"> <li>■ Bayonet ring, stainless steel</li> <li>■ Bayonet ring, polished stainless steel</li> </ul>
<b>Mounting</b>	<ul style="list-style-type: none"> <li>■ Without</li> <li>■ Surface mounting flange, stainless steel</li> <li>■ Panel mounting flange, stainless steel</li> <li>■ Panel mounting flange, polished stainless steel</li> <li>■ Triangular profile ring with mounting bracket, stainless steel <sup>2)</sup></li> <li>■ Triangular profile ring with mounting bracket, polished stainless steel <sup>2)</sup></li> </ul> <p>For information on "Mounting types, mounting flanges, panel cutouts", see technical information IN 00.04</p>
<b>Case filling (model 633.50)</b>	<ul style="list-style-type: none"> <li>■ Without</li> <li>■ Glycerine-water mixture <sup>3)</sup></li> <li>■ Silicone oil <sup>3)</sup></li> </ul>
<b>Movement</b>	<ul style="list-style-type: none"> <li>■ Stainless steel</li> </ul>

1) For general information about NACE standards, see technical information IN 00.21

2) Only for back mount

3) Only available for scale range  $\geq 0 \dots 60$  mbar [0 ... 24 inH<sub>2</sub>O]

Measuring element	
<b>Type of measuring element</b>	Capsule element
<b>Material (wetted)</b>	
Capsule element	Stainless steel 316L
Seal	<ul style="list-style-type: none"> <li>■ FPM/FKM</li> <li>■ PTFE <sup>1)</sup></li> </ul>
Process connection	Stainless steel 316L
<b>Leak tightness</b>	<ul style="list-style-type: none"> <li>■ Leakage rate: <math>&lt; 1 \cdot 10^{-3}</math> mbar l/s</li> <li>■ Helium tested, leakage rate: <math>&lt; 1 \cdot 10^{-5}</math> mbar l/s</li> </ul>

1) For instruments with a required ambient temperature of -40 ... +60 °C [-40 ... +140 °F]

Accuracy specifications	
<b>Accuracy class</b>	
EN 837-3	<ul style="list-style-type: none"> <li>■ Class 1.6</li> <li>■ Class 1.0 <sup>1)</sup></li> </ul>
ASME B40.100	<ul style="list-style-type: none"> <li>■ <math>\pm 2\%</math>   <math>\pm 1\%</math>   <math>\pm 2\%</math> of measuring span (grade A)</li> <li>■ <math>\pm 1\%</math> of measuring span (grade 1A) <sup>1)</sup></li> </ul>
<b>Zero point setting with adjustment screw</b>	<ul style="list-style-type: none"> <li>■ In front, after opening the bayonet ring <sup>2)</sup></li> <li>■ In front, through the opening in the window <sup>3)</sup></li> <li>■ In front, via adjustment screw in the window <sup>4)</sup></li> </ul>
<b>Temperature error</b>	On deviation from the reference conditions at the measuring system: $\leq \pm 0.6\%$ per 10 °C [ $\leq \pm 0.6\%$ per 18 °F] of full scale value
<b>Reference conditions</b>	
Ambient temperature	+20 °C [+68 °F]

1) Selectable for model 632.50 (without case filling) and scale range  $\geq 0 \dots 40$  mbar [0 ... 16 inH<sub>2</sub>O] or for model 633.50 (with case filling) and scale range  $\geq 0 \dots 100$  mbar [0 ... 40 inH<sub>2</sub>O]

2) For model 632.50 (without case filling) and versions without mounting flange

3) For model 632.50 (without case filling) and versions with mounting flange, the opening of the window for the zero point setting is sealed with a taper plug

4) For model 633.50 (with case filling)

## Scale ranges

mbar	
0 ... 2.5 <sup>1)</sup>	0 ... 60
0 ... 4 <sup>1)</sup>	0 ... 100
0 ... 6 <sup>1)</sup>	0 ... 160
0 ... 10 <sup>1)</sup>	0 ... 250
0 ... 16 <sup>2)</sup>	0 ... 400
0 ... 25 <sup>2)</sup>	0 ... 600
0 ... 40	-

kg/cm <sup>2</sup>	
0 ... 0.0025 <sup>1)</sup>	0 ... 0.06
0 ... 0.004 <sup>1)</sup>	0 ... 0.1
0 ... 0.006 <sup>1)</sup>	0 ... 0.16
0 ... 0.01 <sup>1)</sup>	0 ... 0.25
0 ... 0.016 <sup>2)</sup>	0 ... 0.4
0 ... 0.025 <sup>2)</sup>	0 ... 0.6
0 ... 0.04	-

kPa	
0 ... 0.25 <sup>1)</sup>	0 ... 6
0 ... 0.4 <sup>1)</sup>	0 ... 10
0 ... 0.6 <sup>1)</sup>	0 ... 16
0 ... 1 <sup>1)</sup>	0 ... 25
0 ... 1.6 <sup>2)</sup>	0 ... 40
0 ... 2.5 <sup>2)</sup>	0 ... 60
0 ... 4	-

Pa	
0 ... 250 <sup>1)</sup>	0 ... 6,000
0 ... 400 <sup>1)</sup>	0 ... 10,000
0 ... 600 <sup>1)</sup>	0 ... 16,000
0 ... 1,000 <sup>1)</sup>	0 ... 25,000
0 ... 1,600 <sup>2)</sup>	0 ... 40,000
0 ... 2,500 <sup>2)</sup>	0 ... 60,000
0 ... 4,000	-

psi	
0 ... 0.036 <sup>1)</sup>	0 ... 1.0
0 ... 0.06 <sup>1)</sup>	0 ... 1.5
0 ... 0.1 <sup>1)</sup>	0 ... 2.5
0 ... 0.15 <sup>1)</sup>	0 ... 3.6
0 ... 0.25 <sup>2)</sup>	0 ... 6.0
0 ... 0.36 <sup>2)</sup>	0 ... 10
0 ... 0.6	-

mmH <sub>2</sub> O	
0 ... 25 <sup>1)</sup>	0 ... 600
0 ... 40 <sup>1)</sup>	0 ... 1,000
0 ... 60 <sup>1)</sup>	0 ... 1,600
0 ... 100 <sup>1)</sup>	0 ... 2,500
0 ... 160 <sup>2)</sup>	0 ... 4,000
0 ... 250 <sup>2)</sup>	0 ... 6,000
0 ... 400	-

1) Only available for NS 160 [6"]

2) Only available for NS 100 [4"] and NS 160 [6"]

inH <sub>2</sub> O	
0 ... 1 <sup>1)</sup>	0 ... 24
0 ... 1.6 <sup>1)</sup>	0 ... 40
0 ... 2.4 <sup>1)</sup>	0 ... 60
0 ... 4 <sup>1)</sup>	0 ... 100
0 ... 6 <sup>2)</sup>	0 ... 160
0 ... 10 <sup>2)</sup>	0 ... 240
0 ... 16	-

oz/in <sup>2</sup>	
0 ... 0.6 <sup>1)</sup>	0 ... 15
0 ... 1 <sup>1)</sup>	0 ... 25
0 ... 1.5 <sup>1)</sup>	0 ... 40
0 ... 2.5 <sup>1)</sup>	0 ... 60
0 ... 4 <sup>2)</sup>	0 ... 100
0 ... 6 <sup>2)</sup>	0 ... 150
0 ... 10	-

1) Only available for NS 160 [6"]

2) Only available for NS 100 [4"] and NS 160 [6"]

### Vacuum and +/- scale ranges

mbar	
-2.5 ... 0 <sup>1)</sup>	-1.25 ... +1.25 <sup>1)</sup>
-4 ... 0 <sup>1)</sup>	-2 ... +2 <sup>1)</sup>
-6 ... 0 <sup>1)</sup>	-3 ... +3 <sup>1)</sup>
-10 ... 0 <sup>1)</sup>	-5 ... +5 <sup>1)</sup>
-16 ... 0 <sup>2)</sup>	-8 ... +8 <sup>2)</sup>
-25 ... 0 <sup>2)</sup>	-12.5 ... +12.5 <sup>2)</sup>
-40 ... 0	-20 ... +20
-60 ... 0	-30 ... +30
-100 ... 0	-50 ... +50
-160 ... 0	-80 ... +80
-250 ... 0	-125 ... +125
-400 ... 0	-200 ... +200
-600 ... 0	-300 ... +300

kg/cm <sup>2</sup>	
-0.0025 ... 0 <sup>1)</sup>	-0.00125 ... +0.00125 <sup>1)</sup>
-0.004 ... 0 <sup>1)</sup>	-0.002 ... +0.002 <sup>1)</sup>
-0.006 ... 0 <sup>1)</sup>	-0.003 ... +0.003 <sup>1)</sup>
-0.01 ... 0 <sup>1)</sup>	-0.005 ... +0.005 <sup>1)</sup>
-0.016 ... 0 <sup>2)</sup>	-0.008 ... +0.008 <sup>2)</sup>
-0.025 ... 0 <sup>2)</sup>	-0.0125 ... +0.0125 <sup>2)</sup>
-0.04 ... 0	-0.02 ... +0.02
-0.06 ... 0	-0.03 ... +0.03
-0.1 ... 0	-0.05 ... +0.05
-0.16 ... 0	-0.08 ... +0.08
-0.25 ... 0	-0.125 ... +0.125
-0.4 ... 0	-0.2 ... +0.2
-0.6 ... 0	-0.3 ... +0.3

kPa	
-0.25 ... 0 <sup>1)</sup>	-0.125 ... +0.125 <sup>1)</sup>
-0.4 ... 0 <sup>1)</sup>	-0.2 ... +0.2 <sup>1)</sup>
-0.6 ... 0 <sup>1)</sup>	-0.3 ... +0.3 <sup>1)</sup>
-1 ... 0 <sup>1)</sup>	-0.5 ... +0.5 <sup>1)</sup>
-1.6 ... 0 <sup>2)</sup>	-0.8 ... +0.8 <sup>2)</sup>
-2.5 ... 0 <sup>2)</sup>	-1.25 ... +1.25 <sup>2)</sup>
-4 ... 0	-2 ... +2
-6 ... 0	-3 ... +3
-10 ... 0	-5 ... +5
-16 ... 0	-8 ... +8
-25 ... 0	-12.5 ... +12.5
-40 ... 0	-20 ... +20
-60 ... 0	-30 ... +30

Pa	
-250 ... 0 <sup>1)</sup>	-125 ... +125 <sup>1)</sup>
-400 ... 0 <sup>1)</sup>	-200 ... +200 <sup>1)</sup>
-600 ... 0 <sup>1)</sup>	-300 ... +300 <sup>1)</sup>
-1,000 ... 0 <sup>1)</sup>	-500 ... +500 <sup>1)</sup>
-1,600 ... 0 <sup>2)</sup>	-800 ... +800 <sup>2)</sup>
-2,500 ... 0 <sup>2)</sup>	-1,250 ... +1,250 <sup>2)</sup>
-4,000 ... 0	-2,000 ... +2,000
-6,000 ... 0	-3,000 ... +3,000
-10,000 ... 0	-5,000 ... +5,000
-16,000 ... 0	-8,000 ... +8,000
-25,000 ... 0	-12,500 ... +12,500
-40,000 ... 0	-20,000 ... +20,000
-60,000 ... 0	-30,000 ... +30,000

1) Only available for NS 160 [6"]

2) Only available for NS 100 [4"] and NS 160 [6"]

psi	
-0.036 ... 0 <sup>1)</sup>	-0.018 ... +0.018 <sup>1)</sup>
-0.06 ... 0 <sup>1)</sup>	-0.03 ... +0.03 <sup>1)</sup>
-0.1 ... 0 <sup>1)</sup>	-0.05 ... +0.05 <sup>1)</sup>
-0.15 ... 0 <sup>1)</sup>	-0.075 ... +0.075 <sup>1)</sup>
-0.25 ... 0 <sup>2)</sup>	-0.125 ... +0.125 <sup>2)</sup>
-0.36 ... 0 <sup>2)</sup>	-0.18 ... +0.18 <sup>2)</sup>
-0.6 ... 0	-0.3 ... +0.3
-1 ... 0	-0.5 ... +0.5
-1.5 ... 0	-0.75 ... +0.75
-2.5 ... 0	-1.25 ... +1.25
-3.6 ... 0	-1.8 ... +1.8
-6 ... 0	-3 ... +3
-10 ... 0	-5 ... +5

mmH <sub>2</sub> O	
-25 ... 0 <sup>1)</sup>	-12.5 ... +12.5 <sup>1)</sup>
-40 ... 0 <sup>1)</sup>	-20 ... +20 <sup>1)</sup>
-60 ... 0 <sup>1)</sup>	-30 ... +30 <sup>1)</sup>
-100 ... 0 <sup>1)</sup>	-50 ... +50 <sup>1)</sup>
-160 ... 0 <sup>2)</sup>	-80 ... +80 <sup>2)</sup>
-250 ... 0 <sup>2)</sup>	-125 ... +125 <sup>2)</sup>
-400 ... 0	-200 ... +200
-600 ... 0	-300 ... +300
-1,000 ... 0	-500 ... +500
-1,600 ... 0	-800 ... +800
-2,500 ... 0	-1,250 ... +1,250
-4,000 ... 0	-2,000 ... +2,000
-6,000 ... 0	-3,000 ... +3000

inH <sub>2</sub> O	
-1 ... 0 <sup>1)</sup>	-0.5 ... +0.5 <sup>1)</sup>
-1.6 ... 0 <sup>1)</sup>	-0.8 ... +0.8 <sup>1)</sup>
-2.4 ... 0 <sup>1)</sup>	-1.2 ... +1.2 <sup>1)</sup>
-4 ... 0 <sup>1)</sup>	-2 ... +2 <sup>1)</sup>
-6 ... 0 <sup>2)</sup>	-3 ... +3 <sup>2)</sup>
-10 ... 0 <sup>2)</sup>	-5 ... +5 <sup>2)</sup>
-16 ... 0	-8 ... +8
-24 ... 0	-12 ... +12
-40 ... 0	-20 ... +20
-60 ... 0	-30 ... +30
-100 ... 0	-50 ... +50
-160 ... 0	-80 ... +80
-240 ... 0	-120 ... +120

oz/in <sup>2</sup>	
-0.6 ... 0 <sup>1)</sup>	-0.3 ... +0.3 <sup>1)</sup>
-1 ... 0 <sup>1)</sup>	-0.5 ... +0.5 <sup>1)</sup>
-1.5 ... 0 <sup>1)</sup>	-0.75 ... +0.75 <sup>1)</sup>
-2.5 ... 0 <sup>1)</sup>	-1.25 ... +1.25 <sup>1)</sup>
-4 ... 0 <sup>2)</sup>	-2 ... +2 <sup>2)</sup>
-6 ... 0 <sup>2)</sup>	-3 ... +3 <sup>2)</sup>
-10 ... 0	-5 ... +5
-15 ... 0	-7.5 ... +7.5
-25 ... 0	-12.5 ... +12.5
-40 ... 0	-20 ... +20
-60 ... 0	-30 ... +30
-100 ... 0	-50 ... +50
-150 ... 0	-75 ... +75

1) Only available for NS 160 [6"]

2) Only available for NS 100 [4"] and NS 160 [6"]

Further details on: Scale ranges	
<b>Unit</b>	<input type="checkbox"/> mbar <input type="checkbox"/> kg/cm <sup>2</sup> <input type="checkbox"/> kPa <input type="checkbox"/> Pa <input type="checkbox"/> psi <input type="checkbox"/> mmH <sub>2</sub> O <input type="checkbox"/> inH <sub>2</sub> O <input type="checkbox"/> oz/in <sup>2</sup> Other units on request
<b>Overpressure safety</b>	
Scale range < 0 ... 40 mbar [0 ... 16 inH <sub>2</sub> O]	<input type="checkbox"/> Without <input type="checkbox"/> 3 x full scale value
Scale range ≥ 0 ... 40 mbar [0 ... 16 inH <sub>2</sub> O]	<input type="checkbox"/> Without <input type="checkbox"/> 10 x full scale value
<b>Vacuum safety</b>	
Scale range < 0 ... 40 mbar [0 ... 16 inH <sub>2</sub> O]	<input type="checkbox"/> Without <input type="checkbox"/> 3 x full scale value
Scale range ≥ 0 ... 40 mbar [0 ... 16 inH <sub>2</sub> O]	<input type="checkbox"/> Without <input type="checkbox"/> 10 x full scale value

Further details on: Scale ranges		
<b>Dial</b>		
Scale layout	<ul style="list-style-type: none"> <li>■ Single scale</li> <li>■ Dual scale</li> </ul>	
Scale colour	Single scale	Black
	Dual scale	Black/red
Serial number	Consecutive number * ... *	
Material	Aluminium	
Special scale	→ Other scales or customer-specific dials, e.g. with red mark, circular arcs or circular sectors, on request	
<b>Pointer</b>		
Instrument pointer	Aluminium, black	
Mark pointer/drag pointer	<ul style="list-style-type: none"> <li>■ Without</li> <li>■ Red mark pointer on dial, fixed</li> <li>■ Red mark pointer on window, adjustable (only available for NS 100 [4"] and NS 160 [6"])</li> <li>■ Red drag pointer on window, adjustable (only available for scale range <math>\geq 0 \dots 100 \text{ mbar [0 ... 40 inH}_2\text{O)]}</math> <sup>1)</sup></li> </ul>	
<b>Pointer stop pin</b>	<ul style="list-style-type: none"> <li>■ Without</li> <li>■ At zero point</li> <li>■ At 6 o'clock</li> </ul>	

1) With model 633.50 (with case filling) only available for NS 100 [4"] or NS 160 [6"] with positive scale range

Process connection	
<b>Standard</b>	<ul style="list-style-type: none"> <li>■ EN 837-3</li> <li>■ ISO 7</li> <li>■ ANSI/B1.20.1</li> </ul>
<b>Size</b>	
EN 837-3	<ul style="list-style-type: none"> <li>■ G 1/8 B, male thread</li> <li>■ G 1/4 B, male thread</li> <li>■ G 1/2 B, male thread</li> <li>■ M20 x 1.5, male thread</li> </ul>
ISO 7	<ul style="list-style-type: none"> <li>■ R 1/8, male thread</li> <li>■ R 1/4, male thread</li> <li>■ R 1/2, male thread</li> </ul>
ANSI/B1.20.1	<ul style="list-style-type: none"> <li>■ 1/8 NPT, male thread</li> <li>■ 1/4 NPT, male thread</li> <li>■ 1/2 NPT, male thread</li> </ul>
<b>Restrictor</b>	<ul style="list-style-type: none"> <li>■ Without</li> <li>■ <math>\varnothing 0.6 \text{ mm [0.024"]}</math>, stainless steel</li> <li>■ <math>\varnothing 0.3 \text{ mm [0.012"]}</math>, stainless steel</li> </ul>
<b>Material (wetted)</b>	
Capsule element	Stainless steel 316L
Seal	<ul style="list-style-type: none"> <li>■ FPM/FKM</li> <li>■ PTFE <sup>1)</sup></li> </ul>
Process connection	Stainless steel 316L

1) For instruments with a required ambient temperature of  $-40 \dots +60 \text{ }^\circ\text{C} [-40 \dots +140 \text{ }^\circ\text{F}]$

→ Other process connections on request





Operating conditions	
<b>Medium temperature</b>	-20 ... +100 °C [-4 ... +212 °F]
<b>Ambient temperature</b>	
Unfilled instruments	-20 ... +60 °C [-4 ... +140 °F]
Movement wetted with Fomblin® Z03	-40 ... +60 °C [-40 ... +140 °F]
Instruments with silicone filling	-40 ... +60 °C [-40 ... +140 °F]
<b>Pressure limitation</b>	
Steady	Full scale value
Fluctuating	0.9 x full scale value
Short time	1.3 x full scale value
<b>Ingress protection per IEC/EN 60529</b>	<ul style="list-style-type: none"> <li>■ IP54</li> <li>■ IP55</li> <li>■ IP65 <sup>1)</sup></li> </ul>

1) For model 633.50 (with case filling)

## Approvals

Logo	Description	Region
	<b>EU declaration of conformity</b>	European Union
	Pressure Equipment Directive PS > 200 bar, module A, pressure accessory	
	RoHS directive	

### Optional approvals

Logo	Description	Region
 	<b>EU declaration of conformity</b>	European Union
	ATEX directive Hazardous areas Zone 1 gas II 2G Ex h IIC T6 ... T1 Gb Zone 20 dust II 2D Ex h IIIC T85°C ... T450°C Db Ignition protection type "c", constructional safety	
	<b>PAC Kazakhstan</b> Metrology, measurement technology	Kazakhstan
-	<b>MChS</b> Permission for commissioning	Kazakhstan
-	<b>PAC Ukraine</b> Metrology, measurement technology	Ukraine
	<b>PAC Uzbekistan</b> Metrology, measurement technology	Uzbekistan
-	<b>PAC China</b> Metrology, measurement technology	China

## Certificates (option)

Certificates	
<b>Certificates</b>	<ul style="list-style-type: none"> <li>■ 2.2 test report per EN 10204 (e.g. state-of-the-art manufacturing, indication accuracy)</li> <li>■ 3.1 inspection certificate per EN 10204 (e.g. material proof for wetted metal parts, indication accuracy)</li> </ul>
<b>Calibration</b>	<ul style="list-style-type: none"> <li>■ Factory calibration certificate</li> <li>■ SCS calibration certificate (traceable and accredited in accordance with ISO/IEC 17025)</li> <li>■ Calibration certificate by a national accreditation body, traceable and accredited in accordance with ISO/IEC 17025 on request</li> </ul>
<b>Recommended calibration interval</b>	1 year (dependent on conditions of use)

→ For approvals and certificates, see website



## Dimensions in mm [in]

### Lower mount (radial)

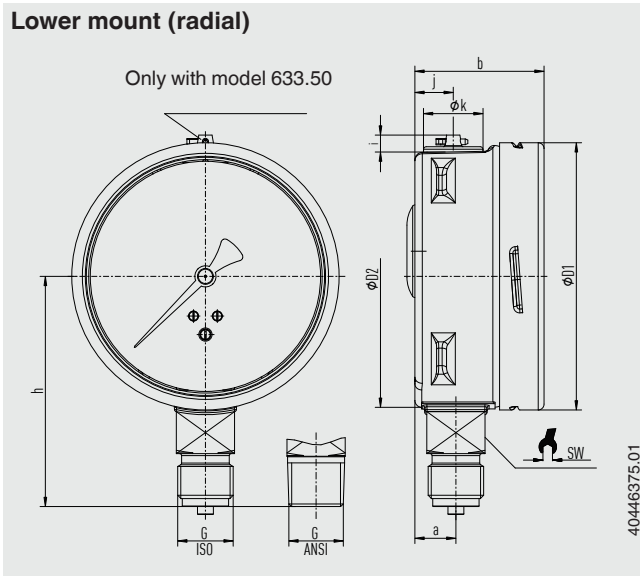

NS	Weight	
	Model 632.50	Model 633.50
63 [2½"]	approx. 0.2 kg [0.44 lb]	approx. 0.26 kg [0.57 lb]
100 [4"]	approx. 0.6 kg [1.32 lb]	approx. 0.8 kg [1.76 lb]
160 [6"]	approx. 1.0 kg [2.2 lb]	approx. 1.7 kg [3.75 lb]

### Process connection with thread per EN 837-3

NS	G	Dimensions in mm [in]									
		h ±1 [0.04]	a	b	D1	D2	i	y	k	SW	
63 [2½"]	G ½ B	49 [1.93]	9.5 [0.37]	43 [1.69]	63 [2.48]	62 [2.44]	6 [0.24]	10 [0.39]	15 [0.59]	14 [0.55]	
	G ¼ B	52 [2.05]	9.5 [0.37]	43 [1.69]	63 [2.48]	62 [2.44]	6 [0.24]	10 [0.39]	15 [0.59]	14 [0.55]	
100 [4"]	G ¼ B	80 [3.15]	15.5 [0.61]	49.5 [1.95]	101 [3.98]	99 [3.9]	6.5 [0.26]	14.5 [0.57]	22.5 [0.89]	22 [0.87]	
	G ½ B	87 [3.43]	15.5 [0.61]	49.5 [1.95]	101 [3.98]	99 [3.9]	6.5 [0.26]	14.5 [0.57]	22.5 [0.89]	22 [0.87]	
	M20 x 1.5	87 [3.43]	15.5 [0.61]	49.5 [1.95]	101 [3.98]	99 [3.9]	6.5 [0.26]	14.5 [0.57]	22.5 [0.89]	22 [0.87]	
160 [6"]	G ¼ B	111 [4.37]	15.5 [0.61]	49.5 [1.95]	161 [6.34]	159 [6.26]	6.5 [0.26]	14.5 [0.57]	22.5 [0.89]	22 [0.87]	
	G ½ B	118 [4.65]	15.5 [0.61]	49.5 [1.95]	161 [6.34]	159 [6.26]	6.5 [0.26]	14.5 [0.57]	22.5 [0.89]	22 [0.87]	
	M20 x 1.5	118 [4.65]	15.5 [0.61]	49.5 [1.95]	161 [6.34]	159 [6.26]	6.5 [0.26]	14.5 [0.57]	22.5 [0.89]	22 [0.87]	

### Process connection with thread per ISO 7

NS	G	Dimensions in mm [in]									
		h ±1 [0.04]	a	b	D1	D2	i	y	k	SW	
63 [2½"]	R ½	49 [1.93]	9.5 [0.37]	43 [1.69]	63 [2.48]	62 [2.44]	6 [0.24]	10 [0.39]	15 [0.59]	14 [0.55]	
	R ¼	52 [2.05]	9.5 [0.37]	43 [1.69]	63 [2.48]	62 [2.44]	6 [0.24]	10 [0.39]	15 [0.59]	14 [0.55]	
100 [4"]	R ¼	80 [3.15]	15.5 [0.61]	49.5 [1.95]	101 [3.98]	99 [3.90]	6.5 [0.26]	14.5 [0.57]	22.5 [0.89]	22 [0.87]	
	R ½	86 [3.39]	15.5 [0.61]	49.5 [1.95]	101 [3.98]	99 [3.90]	6.5 [0.26]	14.5 [0.57]	22.5 [0.89]	22 [0.87]	
160 [6"]	R ¼	111 [4.37]	15.5 [0.61]	49.5 [1.95]	161 [6.34]	159 [6.26]	6.5 [0.26]	14.5 [0.57]	22.5 [0.89]	22 [0.87]	
	R ½	117 [4.60]	15.5 [0.61]	49.5 [1.95]	161 [6.34]	159 [6.26]	6.5 [0.26]	14.5 [0.57]	22.5 [0.89]	22 [0.87]	

### Process connection with thread per ANSI/B1.20.1

NS	G	Dimensions in mm [in]									
		h ±1 [0.04]	a	b	D1	D2	i	y	k	SW	
63 [2½"]	½ NPT	49 [1.93]	9.5 [0.37]	43 [1.69]	63 [2.48]	62 [2.44]	6 [0.24]	10 [0.39]	15 [0.59]	14 [0.55]	
	¼ NPT	52 [2.05]	9.5 [0.37]	43 [1.69]	63 [2.48]	62 [2.44]	6 [0.24]	10 [0.39]	15 [0.59]	14 [0.55]	
100 [4"]	¼ NPT	80 [3.15]	15.5 [0.61]	49.5 [1.95]	101 [3.98]	99 [3.90]	6.5 [0.26]	14.5 [0.57]	22.5 [0.89]	22 [0.87]	
	½ NPT	86 [3.39]	15.5 [0.61]	49.5 [1.95]	101 [3.98]	99 [3.90]	6.5 [0.26]	14.5 [0.57]	22.5 [0.89]	22 [0.87]	
160 [6"]	¼ NPT	111 [4.37]	15.5 [0.61]	49.5 [1.95]	161 [6.34]	159 [6.26]	6.5 [0.26]	14.5 [0.57]	22.5 [0.89]	22 [0.87]	
	½ NPT	117 [4.60]	15.5 [0.61]	49.5 [1.95]	161 [6.34]	159 [6.26]	6.5 [0.26]	14.5 [0.57]	22.5 [0.89]	22 [0.87]	

### NS 63 [2 1/2"], centre back mount

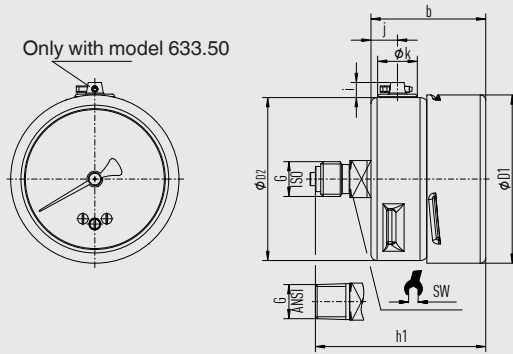

40446374.01

NS	Weight	
	Model 632.50	Model 633.50
63 [2 1/2"]	approx. 0.2 kg [0.44 lb]	approx. 0.26 kg [0.57 lb]

#### Process connection with thread per EN 837-3

NS	G	Dimensions in mm [in]							
		h1 ±1 [0.04]	b	D1	D2	i	y	k	SW
63 [2 1/2"]	G 1/8 B	67 [2.64]	43 [1.69]	63 [2.48]	62 [2.44]	6 [0.24]	10 [0.39]	15 [0.59]	14 [0.55]
	G 1/4 B	72 [2.83]	43 [1.69]	63 [2.48]	62 [2.44]	6 [0.24]	10 [0.39]	15 [0.59]	14 [0.55]

#### Process connection with thread per ISO 7 or ANSI/B1.20.1

NS	G	Dimensions in mm [in]							
		h1 ±1 [0.04]	b	D1	D2	i	y	k	SW
63 [2 1/2"]	R 1/4	70 [2.76]	43 [1.69]	63 [2.48]	62 [2.44]	6 [0.24]	10 [0.39]	15 [0.59]	14 [0.55]

#### Process connection with thread per ISO 7 or ANSI/B1.20.1

NS	G	Dimensions in mm [in]							
		h1 ±1 [0.04]	b	D1	D2	i	y	k	SW
63 [2 1/2"]	1/8 NPT	67 [2.64]	43 [1.69]	63 [2.48]	62 [2.44]	6 [0.24]	10 [0.39]	15 [0.59]	14 [0.55]
	1/4 NPT	70 [2.76]	43 [1.69]	63 [2.48]	62 [2.44]	6 [0.24]	10 [0.39]	15 [0.59]	14 [0.55]

### NS 100 [4"] and NS 160 [6"], lower back mount

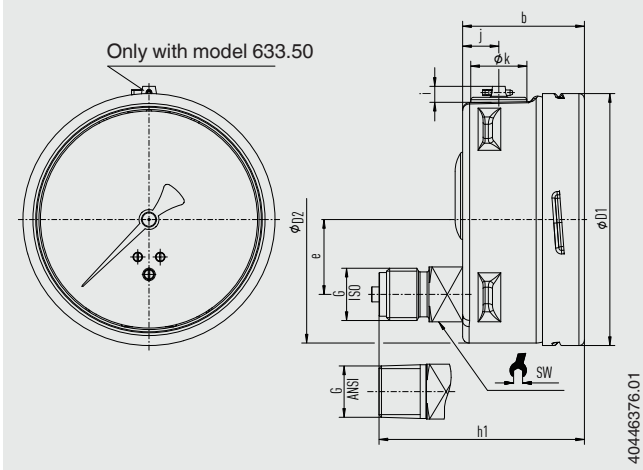

NS	Weight	
	Model 632.50	Model 633.50
100 [4"]	approx. 0.5 kg [1.54 lb]	approx. 0.7 kg [1.54 lb]
160 [6"]	approx. 1.1 kg [2.43 lb]	approx. 1.7 kg [3.75 lb]

### Process connection with thread per EN 837-3

NS	G	Dimensions in mm [in]								
		h1 ±1 [0.04]	b	D1	D2	e	i	y	k	SW
100 [4"]	G ¼ B	76 [2.99]	49.5 [1.95]	101 [3.98]	99 [3.90]	30 [1.181]	6.5 [0.26]	14.5 [0.57]	22.5 [0.89]	22 [0.87]
	G ½ B	83 [3.27]	49.5 [1.95]	101 [3.98]	99 [3.90]	30 [1.181]	6.5 [0.26]	14.5 [0.57]	22.5 [0.89]	22 [0.87]
	M20 x 1.5	83 [3.27]	49.5 [1.95]	101 [3.98]	99 [3.90]	30 [1.181]	6.5 [0.26]	14.5 [0.57]	22.5 [0.89]	22 [0.87]
160 [6"]	G ¼ B	76 [2.99]	49.5 [1.95]	161 [6.34]	159 [6.26]	50 [1.97]	6.5 [0.26]	14.5 [0.57]	22.5 [0.89]	22 [0.87]
	G ½ B	83 [3.27]	49.5 [1.95]	161 [6.34]	159 [6.26]	50 [1.97]	6.5 [0.26]	14.5 [0.57]	22.5 [0.89]	22 [0.87]
	M20 x 1.5	83 [3.27]	49.5 [1.95]	161 [6.34]	159 [6.26]	50 [1.97]	6.5 [0.26]	14.5 [0.57]	22.5 [0.89]	22 [0.87]









### Process connection with thread per ISO 7

NS	G	Dimensions in mm [in]								
		h1 ±1 [0.04]	b	D1	D2	e	i	y	k	SW
100 [4"]	R ¼	76 [2.99]	49.5 [1.95]	101 [3.98]	99 [3.90]	30 [1.181]	6.5 [0.26]	14.5 [0.57]	22.5 [0.89]	22 [0.87]
	R ½	82 [3.23]	49.5 [1.95]	101 [3.98]	99 [3.90]	30 [1.181]	6.5 [0.26]	14.5 [0.57]	22.5 [0.89]	22 [0.87]
160 [6"]	R ¼	76 [2.99]	49.5 [1.95]	161 [6.34]	159 [6.26]	50 [1.97]	6.5 [0.26]	14.5 [0.57]	22.5 [0.89]	22 [0.87]
	R ½	82 [3.23]	49.5 [1.95]	161 [6.34]	159 [6.26]	50 [1.97]	6.5 [0.26]	14.5 [0.57]	22.5 [0.89]	22 [0.87]

### Process connection with thread per ANSI/B1.20.1

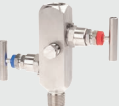
NS	G	Dimensions in mm [in]								
		h1 ±1 [0.04]	b	D1	D2	e	i	y	k	SW
100 [4"]	¼ NPT	76 [2.99]	49.5 [1.95]	101 [3.98]	99 [3.90]	30 [1.181]	6.5 [0.26]	14.5 [0.57]	22.5 [0.89]	22 [0.87]
	½ NPT	82 [3.23]	49.5 [1.95]	101 [3.98]	99 [3.90]	30 [1.181]	6.5 [0.26]	14.5 [0.57]	22.5 [0.89]	22 [0.87]
160 [6"]	¼ NPT	76 [2.99]	49.5 [1.95]	161 [6.34]	159 [6.26]	50 [1.97]	6.5 [0.26]	14.5 [0.57]	22.5 [0.89]	22 [0.87]
	½ NPT	82 [3.23]	49.5 [1.95]	161 [6.34]	159 [6.26]	50 [1.97]	6.5 [0.26]	14.5 [0.57]	22.5 [0.89]	22 [0.87]

## Accessories and spare parts

Model	Description
	<b>910.17</b> Seals → See data sheet AC 09.08
	<b>910.15</b> Syphons → See data sheet AC 09.06
	<b>910.13</b> Overpressure protector → See data sheet AC 09.04
	<b>IV1</b> Needle valve and multipoint valve → See data sheet AC 09.22
	<b>IV2</b> Block-and-bleed valve → See data sheet AC 09.19
	<b>IVM</b> Monoflange, process and instrument version → See data sheet AC 09.17
	<b>BV</b> Ball valve, process and instrument version → See data sheet AC 09.28
	<b>IBF2, IBF3</b> Monoblock with flange connection → See data sheet AC 09.25

### Ordering information

Model / Nominal size / Scale range / Connection location / Process connection / Options

© 12/2008 WIKA Alexander Wiegand SE & Co. KG, all rights reserved.  
 The specifications given in this document represent the state of engineering at the time of publishing.  
 We reserve the right to make modifications to the specifications and materials.  
 In case of a different interpretation of the translated and the English data sheet, the English wording shall prevail.